

FIRE & GAS SCHEDULE		
MARK	QTY	DESCRIPTION
①	1	Fire & Gas Panel
②	1	Fire Extinguisher
③	1	Gas Detector
④	1	Smoke Detector
⑤	2	Thermal Detector

ELECTRICAL/HVAC SCHEDULE		
MARK	QTY	DESCRIPTION
⚡	1	Electrical Panel 120/240V 1-ph (Non-Classified)
⚡	1	HVAC Unit (Non-Classified)

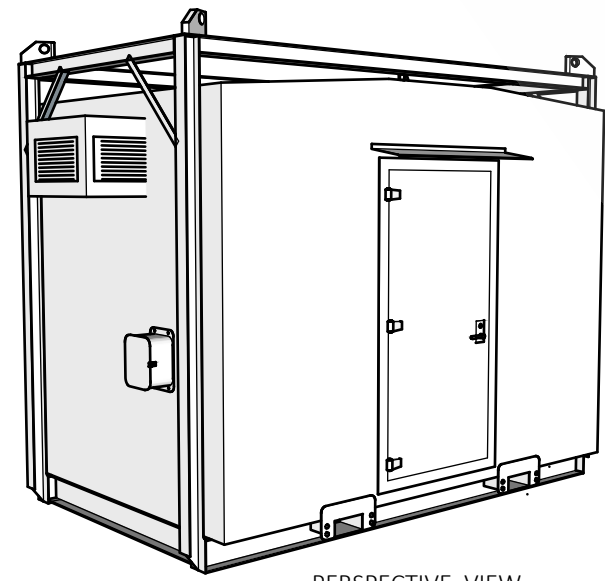

NOTE:  
Building Weight 6,000 lbs.

PERSPECTIVE VIEW  
EXTERIOR ELEVATION

SOUTH VIEW  
EXTERIOR ELEVATION

WEST VIEW  
EXTERIOR ELEVATION

NORTH VIEW  
EXTERIOR ELEVATION

EAST VIEW  
EXTERIOR ELEVATION

REVISION HISTORY		
REV	DATE	DESCRIPTION

**Gulf Land Structures, LLC**  
 PO Box 52605  
 Lafayette, LA 70505-2605  
 4100 Cameron Street  
 Lafayette, LA 70506  
 (337) 993-9858

Designed By: KED Date: 06/21/07  
 Drawn By: KED Date: 05/04/17  
 File Name: GLSR FG Laundry 8x12

**GLS RENTALS DEPARTMENT**

8' x 12' Fiberglass Building  
 Laundry Unit  
 General Arrangement

Page G-1.0
REV A