

10' x 35' 12-PERSON SLEEPER

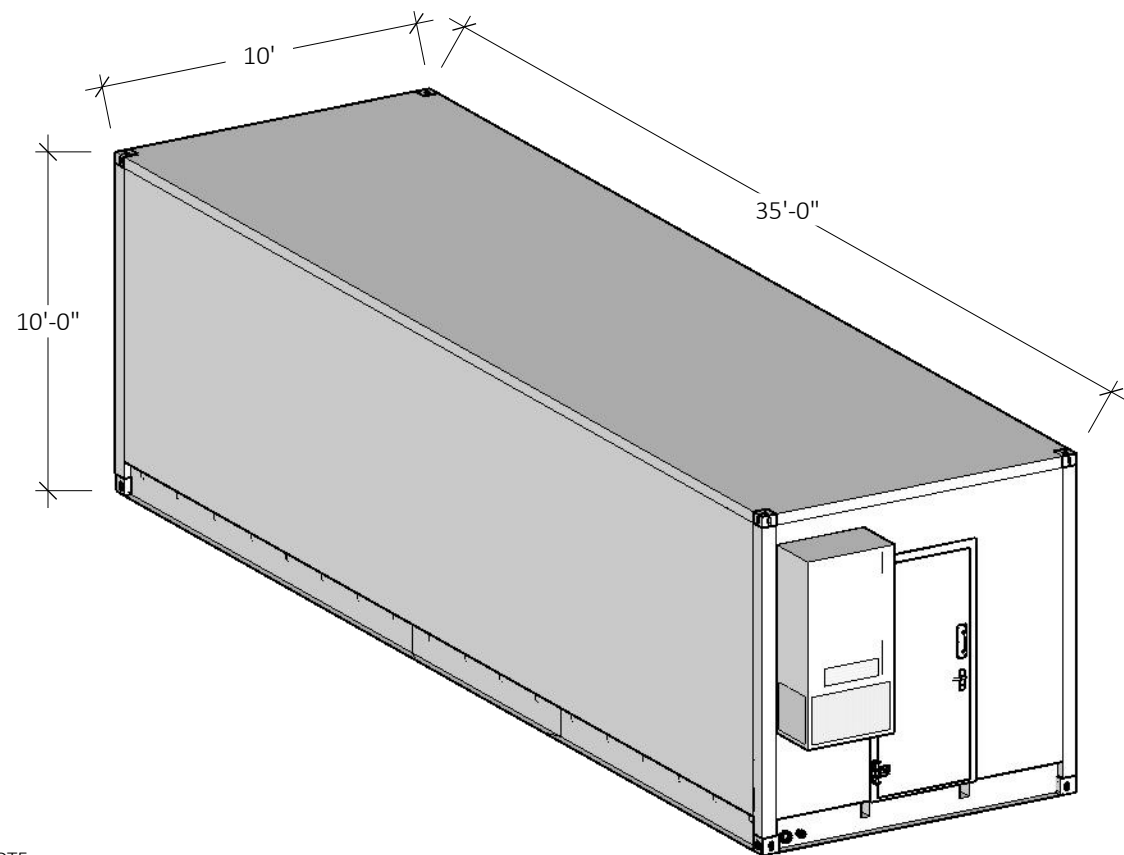

DOOR SCHEDULE		
MARK	QTY	DESCRIPTION
(A)	2	3-0 x 6-8 Exterior Aluminum
(B)	2	2-8 x 6-8 Wood Hollow Core
(C)	0	2-6 x 6-8 Wood Hollow Core
(D)	2	2-0 x 6-8 Wood Hollow Core

FIRE & GAS SCHEDULE		
MARK	QTY	DESCRIPTION
(1)	1	Fire & Gas Panel
(2)	2	Fire Extinguisher
(3)	2	Gas Detector
(4)	2	Smoke Detector
(5)	2	Thermal Detector
(6)	0	Manual Pull Station
(7)	2	Strobe/Horn

FURNISHINGS SCHEDULE		
MARK	QTY	DESCRIPTION
(1)	12	Bunk Shelf
(2)	6	Double Stack Locker
(3)	6	Double Bunk Bed
(4)	2	Water Heater
(5)	2	Vanity Cabinet with Sink & Mirror
(6)	2	Shower 36"
(7)	2	Toilet with Upper Shelf
(8)	1	Bench with Upper Shelf

ELECTRICAL/HVAC SCHEDULE		
MARK	QTY	DESCRIPTION
(A)	1	Electrical Panel 120/240V 1-ph (Non-Classified)
(B)	1	HVAC Unit (Non-Classified)

REVISION HISTORY		
REV	DATE	DESCRIPTION
01	11/04/21	Issued for review

**Gulf Land Structures, LLC**  
 PO Box 52605  
 Lafayette, LA 70505-2605  
 4100 Cameron Street  
 Lafayette, LA 70506  
 (337) 993-9858

Designed By: KED Date: 11/04/21  
 Drawn By: KED Date: 11/04/21  
 File Name: 3057-01 1009-2021 12-Bed Splr Alum 10x35

**GLS RENTALS DEPARTMENT**

10' x 35' Aluminum  
 GLS Rentals  
 12-Person Sleeper  
 General Arrangement

Drawing A-1.0  
 REV 01

NOTE:  
 Typical Single Building Weight 15,700 lbs.